

NOTES:

- BLOW-OFF HYDRANTS SHALL BE ECLIPSE NO. 85 BOX HYDRANT AS MANUFACTURED BY JOHN C. KUPFERLE FOUNDRY COMPANY, ST. LOUIS, MO.
- HYDRANTS SHALL BE SELF-DRAINING, NON-FREEZING, COMPRESSION TYPE WITH 2-3/16" MAIN VALVE OPENING. INLET CONNECTION SHALL BE (1-1/4" IP, 1-1/2" IP, 2" IP, 2-1/2" IP, 3" IP, 2" M, OR 3" M). OUTLET SIZE SHALL BE (ANY SIZE UP TO 2-1/2" NST).
- HYDRANT SHALL HAVE CAST IRON BOX, LOCKING LID, AND 3" SCHEDULE 80 PVC RISER PIPE (3" DUCTILE IRON PIPE ALSO AVAILABLE). PRINCIPAL INTERIOR OPERATING PARTS SHALL BE BRASS AND REMOVABLE FROM THE HYDRANT FOR SERVICING WITHOUT EXCAVATING THE HYDRANT.
- HYDRANTS SHALL BE SET IN 4 CUBIC FEET OF CRUSHED STONE TO ALLOW FOR PROPER DRAINAGE OF THE HYDRANT. RECOMMENDATIONS OF THE AWWA SHOULD BE FOLLOWED FOR INSTALLATION OF THE HYDRANTS.

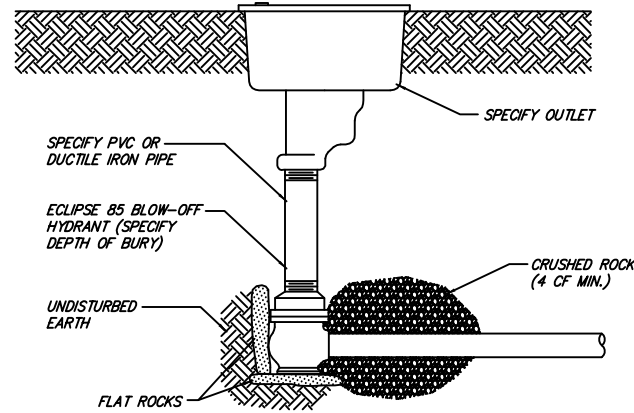

ECLIPSE BLOW-OFF HYDRANT
N.T.S.
WA.3.1

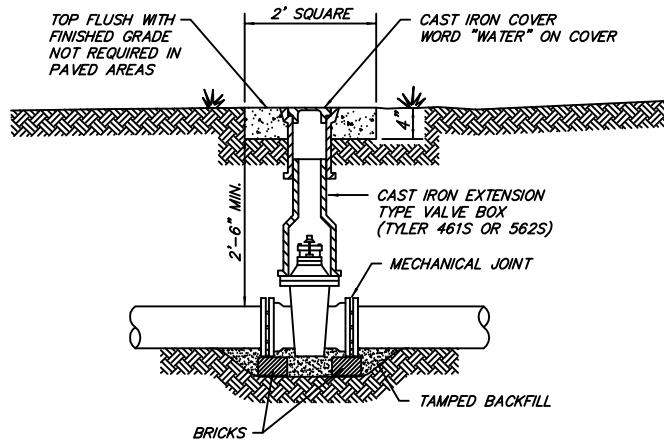

TYPICAL GATE VALVE
N.T.S.
WA.3.2

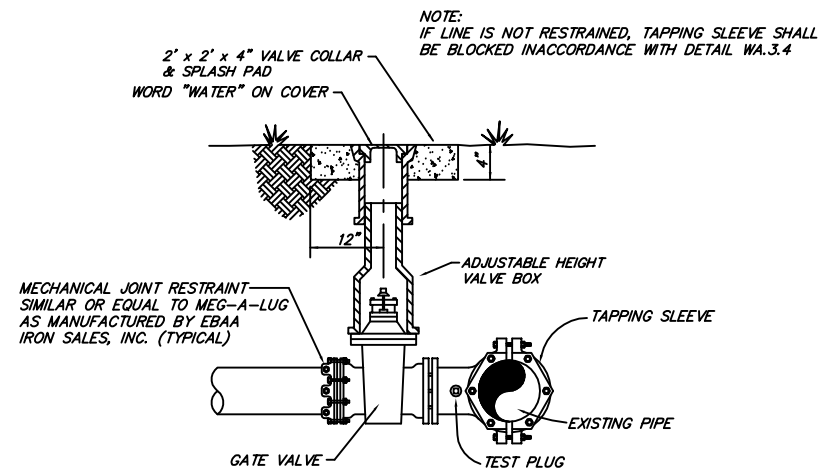

TAPPING SLEEVE & VALVE
N.T.S.
WA.3.3

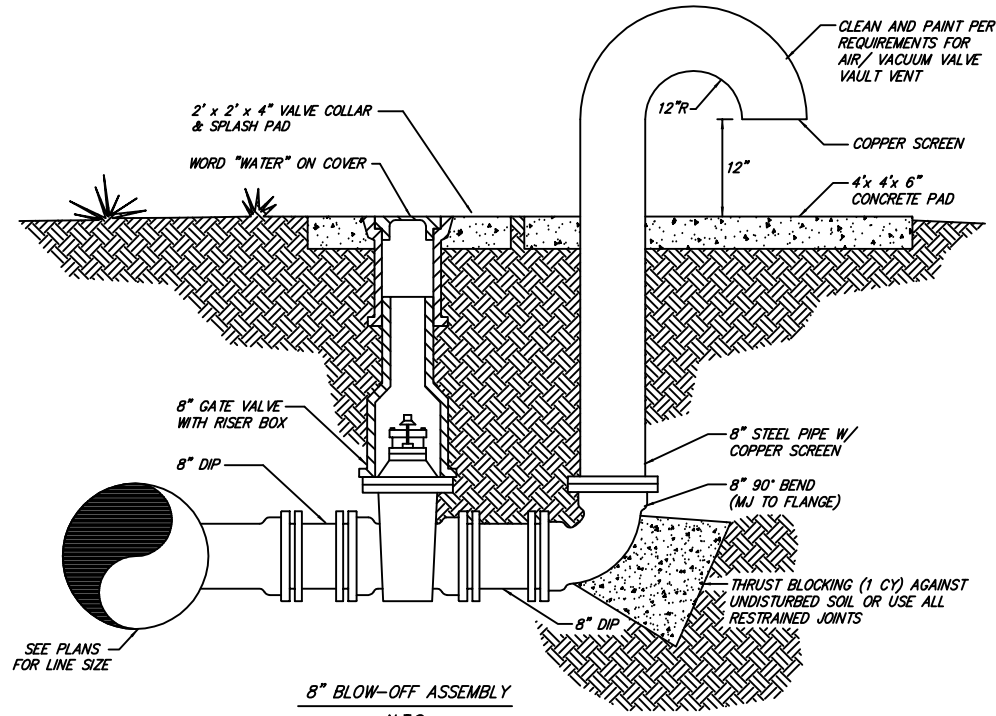

8" BLOW-OFF ASSEMBLY
N.T.S.
WA.3.4

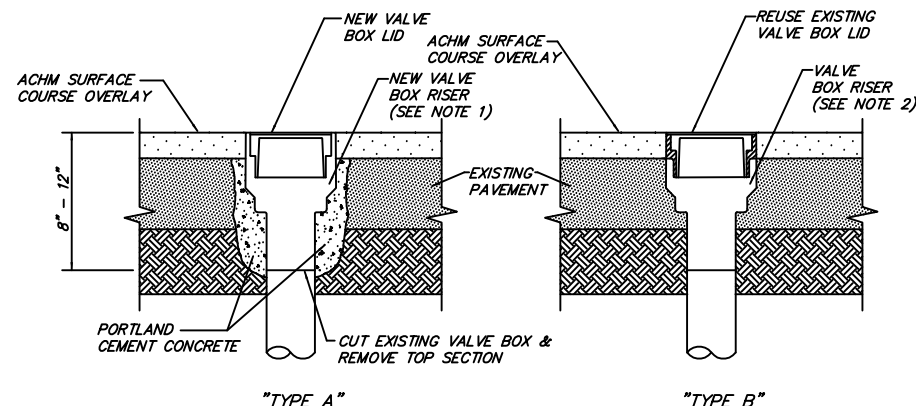

NOTES

- VALVE BOX RISER FOR TYPE "A" ADJUSTMENT SHALL BE SLIP TYPE RISER FOR 5-1/4" SHAFT VALVE BOX & SHALL BE SIMILAR AND EQUAL TO TYLER MODEL 68-A. RISER SHALL BE CUT TO LENGTH AS REQUIRED.
- VALVE BOX RISER FOR TYPE "B" ADJUSTMENT SHALL BE SIMILAR AND EQUAL TO TYLER 2-1/4" RISER FOR 5-1/4" SHAFT VALVE BOXES.
- VALVE BOX LIDS SHALL BE STANDARD DROP LIDS WITH "WATER" INSCRIBED ON THE TOP.

VALVE BOX ADJUSTMENT
N.T.S.
WA.3.5

AIR/VACUUM VALVE ASSEMBLY NOTES

- CONTRACTOR SHALL BACKFILL OVER THE WATER LINE WITH GRAVEL TO A POINT 12-INCHES (MINIMUM) ABOVE THE TOP OF PIPE. A CONCRETE FOUNDATION PAD AND VAULT SHALL THEN BE CONSTRUCTED OVER THE WATER LINE. THE VAULT SHALL CONSIST OF A SECTION OF 72-INCH REINFORCED CONCRETE PIPE (RCP), CLASS 3 WITH A FIELD CONSTRUCTED TOP SLAB. THE TOP SLAB SHALL INCLUDE LIFTING EYES, AN 8-INCH STEEL VENT, AND A 24-INCH HEAVY DUTY MANHOLE RIM WITH BOLT-DOWN LID. THE 6 INCH STEEL VENT PIPE SHALL BE CLEANED AND PAINTED WITH SHERWIN-WILLIAMS, RUST-OLEUM OR EQUIVALENT PAINT. PAINT SHALL BE EPOXY SUITABLE FOR EXTERIOR USAGE, AND APPLIED IN A MINIMUM OF (2) COATS, 4-MILS DRY EACH.
- FOR EACH AIR/VACUUM VALVE VAULT, THE CONTRACTOR SHALL TAP THE WATER LINE, PROVIDE A FACTORY INSTALLED WELDED FLANGE OUTLET, OR INSTALL A RESTRAINED JOINT TEE. A FLANGED DUCTILE IRON PIPE EXTENSION SHALL BE INSTALLED ON THE TAP TO RAISE THE ISOLATION VALVE ABOVE THE LEVEL OF THE VAULT'S BOTTOM SLAB. THE TAPPING SADDLE, FACTORY WELDED FLANGE OUTLET, OR TEE SHALL BE CONSIDERED INCIDENTAL TO THE COST OF THE VAULT AND WILL NOT BE PAID FOR SEPARATELY.
- CONTRACTOR SHALL INSTALL A COMBINATION AIR VALVE OF THE SIZE AND TYPE SHOWN ON THE PLANS. THE VALVE SHALL INCLUDE AN ISOLATION BUTTERFLY VALVE AND ANTI-SLAM DEVICE WHERE REQUIRED.
- IF VAULT IS INSTALLED IN PAVED AREA, VENT SHALL BE INSTALLED THRU WALL OF VAULT AND RUN AT A 2% SLOPE OUT A MINIMUM OF 3' BEYOND THE PAVED AREA.

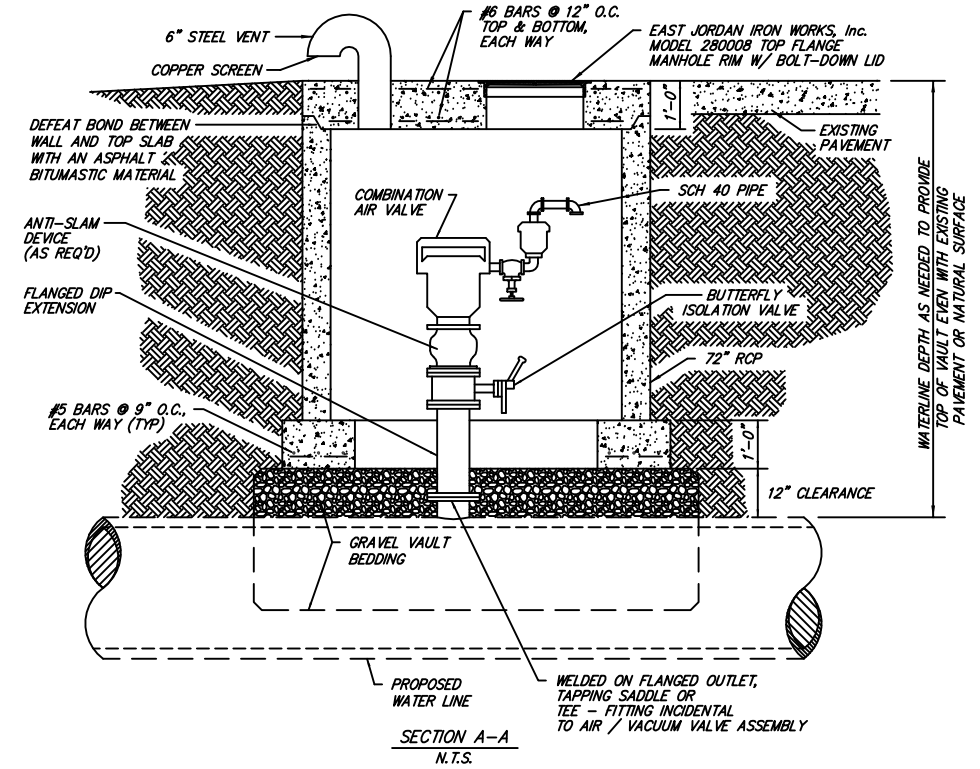

SECTION A-A
N.T.S.

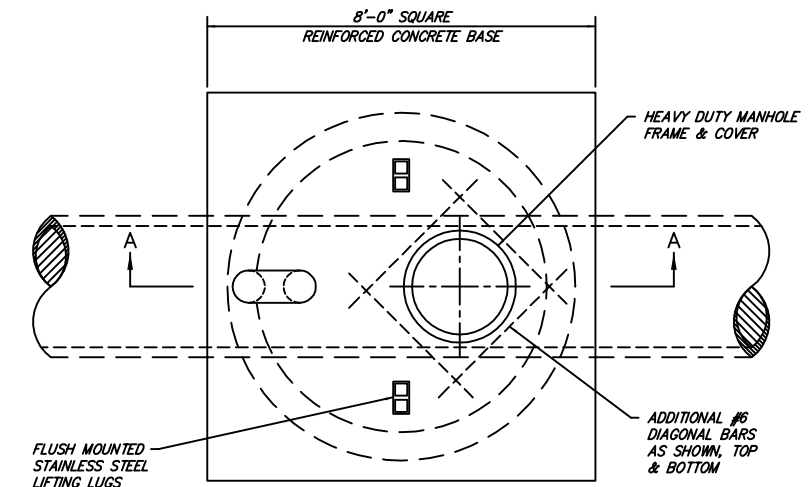

AIR/VACUUM VALVE ASSEMBLY
N.T.S.
WA.3.6

Revision	Date	BY

Standard Drawings
WATER SYSTEM IMPROVEMENTS
Public Works Construction



CITY OF FORT SMITH
Engineering Department
623 Garrison Avenue, Room 409
Fort Smith, Arkansas 72901
Phone (479)784-2225 Fax (479)784-2245

Project:	Details
Date:	NOV 2012
Scale:	As Shown
Drawn By:	RBR
Dwg. No.:	WA3
Sheet No.:	40

11/09/12-13:33 RBR
 G:\DRAWINGS\00-Standard Details\2008\2012\DWG\00-WA3.dwg